

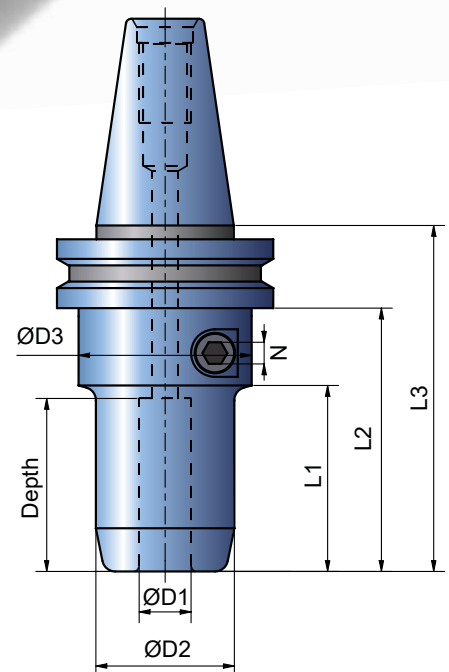

**Tough  
and compact  
design**

### Benefits and features

- Quick and easy tool change
- High performance
- Slender design
- Excellent runout



## ETP HYDRO-GRIP® SLENDER SK30

HYDRO-GRIP type SLENDER is extremely user friendly which means quick and easy tool changes. It has a tough and compact design and it is the most slender chuck in our range. A safety feature prevents the tool from falling out when the chuck is not pressurized. The tool shank must be equipped with a thread corresponding to the safety screw size.

### Technical specification ETP HYDRO-GRIP® SLENDER SK30

Dimensions, mm

Part.no	Item description	D1	D2	D3	L1	L2	L3	Depth*	N	Max rpm
701833	SLENDER-12/SK30	12	32	40	43	60,9	80	40	5	25000
702726	SLENDER-16/SK30	16	38	40	43	60,9	80	40	5	25000
702750	SLENDER-20/SK30	20	40	50	55	95,9	115	52	5	25000
701857	SLENDER-25/SK30	25	45	50	59	99,9	119	56	5	25000
702070	SLENDER-3/8"/SK30	3/8"	32	40	43	60,9	80	40	5	25000
702071	SLENDER-1/2"/SK30	1/2"	32	40	43	60,9	80	40	5	25000
702159	SLENDER-3/4"/SK30	3/4"	40	50	55	95,9	115	52	5	25000
703626	SLENDER-1"/SK30	1"	45	50	59	99,9	119	56	5	25000

\*)= clamping length

- The runout is measured at 3xD and the max runout is  $\leq 0,006$  mm (0.00024 inch).
- The type SLENDER chuck is balanced to G2,5 at 25000 rpm.
- A normally balanced chuck and tool can be used up to a max. speed of 25000 rpm.
- Can be used with reduction sleeves, see page 15-16 for assortment.

● From stock

### TOLERANCES

The SLENDER chuck is designed and manufactured for a router bit shank with the tolerance g6 (h7). Transmittable torque for tools with tolerances:

Type	h6	h7	g6	Safety screw
<b>D</b>	<b>Nm</b>	<b>Nm</b>	<b>Nm</b>	<b>ISO 4762</b>
12	60	30	30	M6x40
16	100	75	75	M6x40
20	260	175	175	M8x45
25	480	350	350	M8x45
3/8"	30	15	15	M6x40
1/2"	60	30	30	M6x40
3/4"	260	175	175	M8x45
1"	480	350	350	M8x45