



Benefits and features

- World famous safety device
- Compact design
- Quick, safe and easy tool change
- Perfect runout and repeatability

ETP HYDRO-GRIP® G3 HSK 63F

HYDRO-GRIP type G3 is historically very tough but the new generation has an even more compact design. The hydraulic chuck is equipped with our well known built in safety device. The safety device prevents the tool from falling out when the chuck is not pressurized. Pressurizing is carried out with an allen T-wrench. The G3 chuck allows quick, safe and easy tool changes and perfect runout and repeatability.

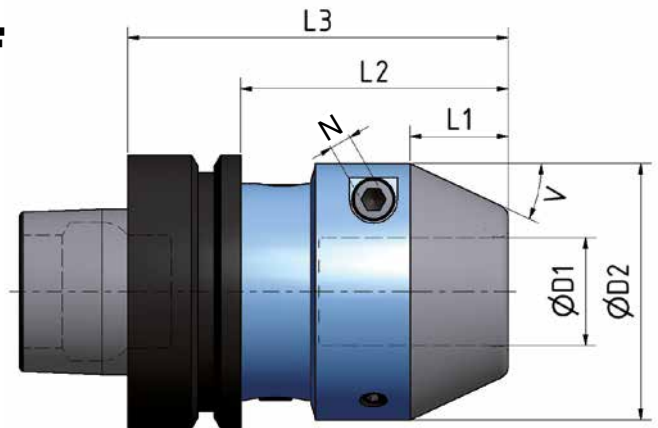

Technical specification ETP HYDRO-GRIP® G3 HSK 63F

Part.no	Item description	Dimensions, mm								
		D1	D2	L1	L2	L3	V	Depth *	N	Max rpm
53146	G3-12/HSK63F	12	45	3	42	68	70	24	5	25000
53226	G3-16/HSK63F	16	48	9	48	74	45	30	5	25000
53306	G3-20/HSK63F	20	52	15	54	80	30	36	5	25000
53406	G3-25/HSK63F	25	59	22,5	61,5	87,5	25	43,5	5	25000
665720	G3-3/8"/HSK63F	3/8"	45	3	42	68	70	24	5	25000
54146	G3-1/2"/HSK63F	1/2"	45	4,5	43,5	69,5	65	25,5	5	25000
54266	G3-3/4"/HSK63F	3/4"	52	13,5	52,5	78,5	35	34,5	5	25000
54406	G3-1"/HSK63F	1"	59	22,5	61,5	87,5	25	43,5	5	25000

*)= clamping length
 • The runout is measured at 3xD and the max runout is ≤ 0,006 mm (0.00024 inch).
 • The type G3 chuck is balanced to G2,5 at 25000 rpm.
 • A normally balanced chuck and tool can be used up to a max. speed of 25000 rpm.

● From stock

TOLERANCES

The type G3 chuck is designed and manufactured for a router bit shank with the tolerance g6 (h7). Transmittable torque for tools with tolerances:

Type	h6	h7	g6
D	Nm	Nm	Nm
12	25	15	15
16	80	60	60
20	185	125	125
25	400	300	300
3/8"	16	7	7
1/2"	25	15	15
3/4"	185	125	125
1"	400	300	300