



**Benefits and features**

- Fit your tools quick and easy
- Stainless steel
- Can be ultrasonically cleaned
- Practical handling with flat balance surface

**ETP HYDRO-GRIP® CIR**

ETP HYDRO-GRIP is manufactured in stainless steel and perfect for use in demanding environments.

Sleeve for **interchangeable tool assembly** that can be used with different tools. The tool should be bolted to the sleeve's collar. Several tools can be mounted simultaneously. Pressurizing is carried out with an allen T-wrench.

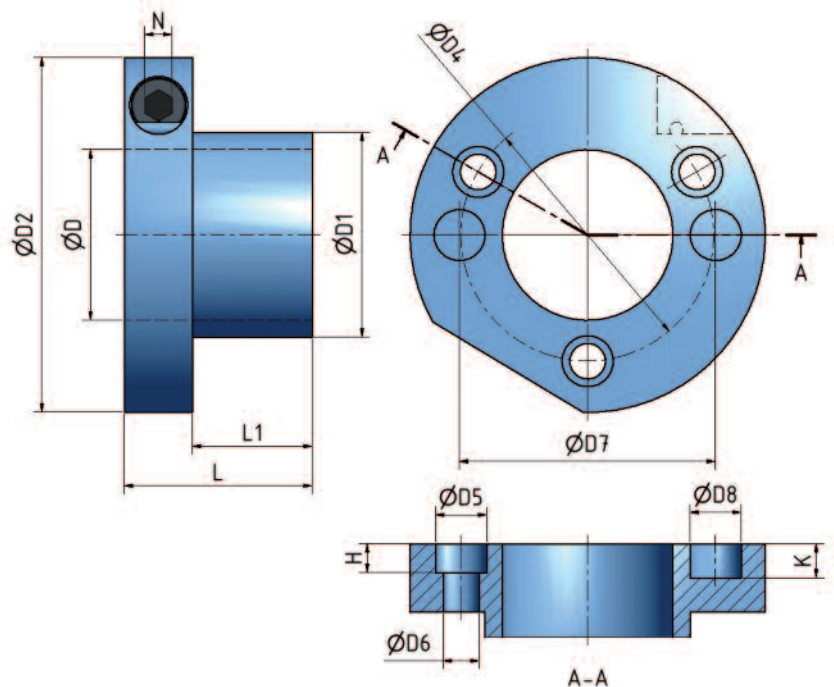

**Technical specification ETP HYDRO-GRIP® CIR Stainless steel**

Type	D	D1	D2	D4	D5	D6	D7	D8	H	K	L	L1	N
CIR-50/60-75*	50	60	104	74	14	10.5	75	15	8.5	10	75	55	8
CIR 1 13/16"/60-75	1 13/16"	60	104	74	14	10.5	75	15	8.5	10	75	55	8

\*) The CIR Ø50 has two, threaded M5-holes for carrier pegs, on a 70 mm pitch diameter. See page 44 for more information.